



CITY OF CANYON LAKE

City Hall

31516 Railroad Canyon Road

Canyon Lake, CA 92587

Website: www.cityofcanyonlake.org

Chair Larry Greene
Member Jeremy Smith

AGENDA

Regular Meeting of the Finance & Planning Committee

Tuesday, March 5, 2019

8:00 A.M.

COUNCIL CHAMBER

CALL TO ORDER

PLEDGE OF ALLEGIANCE

ROLL CALL

PUBLIC COMMENT

Limit 3 Minutes

ROUTINE ITEMS

- (1) Accept Meeting Minutes
 - February 5, 2019
- (2) Update by Interwest
- (3) Review of March 6, 2019 Council Meeting Agenda
 - Claims & Demands
 - Credit Card Review
 - Investment Report
 - Expense Report
- (4) Authorization to Purchase Golf Community Caution Signs with Statewide Traffic Safety & Signs
- (5) Discussion of Goetz Rd. Light Signal Configuration Change
- (6) Discussion of Lease Proposal with Dish Network

STAFF COMMENTS

COMMITTEE MEMBER COMMENTS

ADJOURNMENT

Next Meeting Date: **April 2, 2019**

MINUTES
REGULAR MEETING OF THE CANYON LAKE
FINANCE & PLANNING COMMITTEE
Tuesday, February 5, 2019
8:00 a.m.

City Council Chamber
31516 Railroad Canyon Road
Canyon Lake, CA 92587

CALL TO ORDER

Committee Chair Greene called the meeting to order at 8:00 a.m.

PLEDGE OF ALLEGIANCE

Committee Member Smith led the flag salute.

ROLL CALL

Present: Committee Chair Greene
 Committee Member Smith

PUBLIC COMMENTS

There were no public comments.

1. Accept Meeting Minutes

- January 1, 2019
- January 8, 2019

The minutes were accepted as presented.

2. Update by Interwest Associates

Gil Petris, Building Official, provided a handout to the Committee and presented the statistics from the Building Department for the month of January.

Committee Chair Greene questioned the POA projects and if there are any delays.

Petris stated that there is an issue with one of their projects in which a canopy was relocated and the City was not called for a final inspection.

Committee Chair Greene questioned the 180 open permits which were not closed by the previous predecessor. Discussion ensued.

Councilmember Smith circled back to permit # 2018-320 and questioned what needs to be done to have efficient communication with the POA.

Petris stated that he will be meeting with the POA to address the issues. Discussion regarding the City's communication process with the POA continued.

Committee Chair Greene questioned the status of the transition from Charles Abbott & Associates to Interwest. Discussion ensued.

Committee Chair Greene offered the Committee's assistance in any way possible.

Lastly, Petris gave an update on the issue with the property located on Gray Fox and stated that the City had an appointment however, the owner cancelled at the last minute and has not called back to reschedule.

Committee Chair Greene acknowledged that there is now someone in the audience and asked that person if he wanted to introduce himself.

Chris Mann introduced himself and stated that he is a candidate for the City Manager position and was there to learn as much as possible.

3. Review of February 6, 2019 Council Meeting Agenda – Recommendations to Council

Claims and Demands

There was discussion regarding the costs incurred by Charles Abbott Associates, Inc.

Committee Chair Greene mentioned that there were issues with delinquent bills due to the City's internal process. Discussion regarding the way the City processes bills ensued.

Committee Chair Greene questioned the cost for Sheltering on page 19.

Terry Shea, Finance Director stated that this is a quarterly cost based on population.

There was discussion regarding the cost for propane from AmeriGas.

There was discussion regarding Charles Abbott's cost for the City's software.

There was discussion regarding the blood testing costs from the Sheriff's Department.

There was a brief discussion regarding Data Ticket.

Councilmember Smith stated that he did follow up with the POA regarding Janitorial Services and determined that the City's current contract is just fine.

Committee Chair Greene stated that the City will need to contract with someone to provide Maintenance Services at mid-year. He will contact the POA to get further information on their contract for maintenance services.

There was discussion regarding the \$5,000 cost for landscaping.

Committee Chair Greene questioned the invoice for Riverside County Fire and the date it was received versus the date it was actually paid.

Committee Chair Greene circled back to the Water Irrigation costs on page 23 and stated that there was a water leak. There was also a late fee caused by the City's policy on processing checks which was mentioned earlier. Discussion regarding the leak ensued.

There was further discussion regarding the late fees which are being incurred on utility bills due to the City's policy on processing checks and methods to avoid those fees.

Credit Card Review

There were no comments

Investment Report

Committee Chair Greene questioned page 47 and the status of moving away from Citizens Trust.

Shea stated that there are items on this agenda and the February 6th City Council agenda that will authorize for them to open a new account. It will take approximately 30 days to have everything moved over. The City will see an annual cost saving of \$10,000.00.

Committee Chair Greene had questions regarding the City's notification of fraud use and who is currently being notified in case of fraud. Discussion ensued.

Expense Report Review

There were no comments.

Utility User Tax Update

There were no comments.

4. Review of Fiscal Year 2017-18 Audited Financial Statements

Shea presented the final audit and stated the numbers have not changed from the draft documents which were presented last month. The only change is the final document which contains the auditor's opinions. Page 70 reflects the auditor's unmodified opinion. Discussion regarding the final audit ensued.

Committee Chair Greene commented about a proposed bill which would hold a City's gas tax if their Housing Element has not been met. Discussion ensued.

There was discussion regarding the Sheriff's Department and the impacts of their rates on cities in Riverside County.

5. Agreement with Multi-Bank Securities, Inc. & Opening a Custodial Agreement with Pershing LLC

There were no comments on this item.

6. Discussion of Housing Element Notice of Noncompliance

Committee Chair Greene stated that a letter was sent to the City quite some time ago notifying that it's out of compliance with its housing element. This item will go before Council to approve a contract with Castaneda & Associates for their services to complete a new plan.

7. Authorization of Professional Service Agreement with iWorQ and Termination of Existing Software Solutions with CAA

Staff is recommending the purchase of this software for Business Licenses, Code Enforcement, and Animal Licenses to replace the City's current software solutions with Charles Abbott & Associates, Inc.

Councilmember Smith requested a presentation from iWorQ at the City Council Meeting.

Ana Sauseda, Deputy City Clerk, will check with staff to verify is a presentation on such short notice is possible.

8. Authorization of Professional Service Agreement with PZL Inc. for Planning Services in the Building & Safety Department

There was brief discussion regarding the contract.

9. Discussion of Golf Community Caution Signs on Railroad Canyon Road

Committee Member Smith is proposing the purchase of two signs to be placed on each side of Railroad Canyon Road as drivers enter the City to notify them that they are entering a Golf Cart Community. Discussion ensued.

10. Discussion of Implementing an Internship Program for City Hall

Committee Member Smith stated that the City met with Samantha who is the District Director for Melissa Melendez to discuss starting an internship program in conjunction

with the POA and Chamber of Commerce as well. Discussion regarding the details of the program ensued.

11. Discussion of Claims & Demands Process

There was brief discussion of different options for avoiding late fees.

COMMITTEE MEMBER COMMENTS

Committee Chair Greene stated that they would really like to see a presentation from iWorQ at the City Council Meeting.

There was discussion of the City's mid-year review process.

Committee Member Smith stated that he received a request from Councilmember Bonner for the City to research setting aside approximately \$20,000.00 for I-15 projects.

Committee Chair Greene questioned if Gas Tax funds can be used for Councilmember Bonner's request. Discussion ensued.

Committee Member Smith questioned if the City is grant hunting. Discussion ensued.

STAFF COMMENTS

There were no comments.

ADJOURNMENT

The meeting was adjourned at 9:22 a.m.

Respectfully Submitted,

Ana V. Sauseda,
Deputy City Clerk

City of Canyon Lake
City Council
Staff Report

TO: Finance & Planning Committee
FROM: Mike Borja, Acting City Manager
BY: Lisa Casillas, Accountant
DATE: March 5, 2019
SUBJECT: List of Demands



Recommendation:

That the City Council adopt a resolution entitled: RESOLUTION NO. 2019-05

A RESOLUTION OF THE CITY COUNCIL OF THE
CITY OF CANYON LAKE ALLOWING CERTAIN
CLAIMS AND DEMANDS AS SET FORTH IN EXHIBIT A

Background:

All claims and demands are reported and summarized for review and approval by the City Council on a routine basis at each City Council meeting. The attached claims represent the paid claims and demands since the City Council meeting of February 6, 2019.

Budget (or Fiscal) Impact:

All claims and demands are paid from appropriated funds or authorized resources of the City and have been recorded in accordance with the City's policies.

Attachments:

1. Resolution No. 2019-05
2. List of Demands

RESOLUTION NO. 2019-05

A RESOLUTION OF THE CITY COUNCIL OF THE CITY OF CANYON LAKE, CALIFORNIA, ALLOWING CERTAIN CLAIMS AND DEMANDS AS SET FORTH IN EXHIBIT A

The City Council of the City of Canyon Lake does hereby resolve as follows:

Demands are approved as shown on the Demand/Warrant Register of March 6th, in the amount of \$413,985.24 as follows:

Payroll Earnings (Gross)	\$ 43,715.28	(2nd Half of January & 1st Half of February)
Payroll Taxes - Employer	1,986.92	(2nd Half of January & 1st Half of February)
On-line Retirement	4,580.28	(2nd Half of January & 1st Half of February)
On-line Health	136.69	(For the Month of February)
Nationwide Deferred Comp.	352.84	(For the Month of January)
General	363,213.23	
TOTAL	<u>\$ 413,985.24</u>	

PASSED, APPROVED AND ADOPTED this 6th day of March, 2019.

ATTEST:

Larry Greene, Mayor

Ana V. Sauseda, Deputy City Clerk

State of California
County of Riverside) ss
City of Canyon Lake)

I, Ana V. Sauseda, Deputy City Clerk of the City of Canyon Lake, California, DO HEREBY CERTIFY, that the foregoing is a true and correct copy of the Resolution No. 2019-05 adopted by the City Council of the City of Canyon Lake, California, at a regular meeting thereof, held on March 6, 2019, by the following vote:

AYES:
NOES:
ABSTAIN:
ABSENT:

Ana V. Sauseda, Deputy City Clerk

CLAIMS AND DEMANDS

City of Canyon Lake
 Check/Voucher Register - Council Report - Expenditures
 From 2/1/2019 Through 2/28/2019

Check Num...	Matching Docum... Date	Vendor Name	Transaction Description	Check Amount	Fund Code	Fund Short Title
24839	2/6/2019	Aflac	Supplemental Insurance January 2019	378.22	10	GENERAL
Total 24839	2/6/2019			378.22		
24840	2/6/2019	AMERICAN FORENSIC NURSES INC	Sheriff's Blood Draws December 2018	55.00	10	GENERAL
Total 24840	2/6/2019			55.00		
24841	2/6/2019	Control Pump	Install Interior Lighting	1,985.90	20	GAS TAX
24841	2/6/2019	Control Pump	Install PLC/HMI Upgrade	21,681.00	20	GAS TAX
24841	2/6/2019	Control Pump	Replace Faulty Limit Switch on Amiad Filter	464.00	20	GAS TAX
Total 24841	2/6/2019			24,130.90		
24842	2/6/2019	Corelogic Information Solutions, INC.	Code Enforcement Data Base January 2019	130.00	10	GENERAL
Total 24842	2/6/2019			130.00		
24843	2/6/2019	CTAI Pacific Greenscape	Fire Station Landscape Maintenance Service January 2019	250.00	10	GENERAL
24843	2/6/2019	CTAI Pacific Greenscape	Cleanup Trees and Debris	1,100.00	20	GAS TAX
24843	2/6/2019	CTAI Pacific Greenscape	Emergency Boulder Removal	250.00	20	GAS TAX
24843	2/6/2019	CTAI Pacific Greenscape	Median and Parkways Landscape Maintenance Service Jan 2019	5,000.00	20	GAS TAX
Total 24843	2/6/2019			6,600.00		
24844	2/6/2019	THE GAS COMPANY	Gas, 12/31/18-1/30/19	178.21	10	GENERAL
Total 24844	2/6/2019			178.21		

City of Canyon Lake
 Check/Voucher Register - Council Report - Expenditures
 From 2/1/2019 Through 2/28/2019

Check Num...	Matching Docum... Date	Vendor Name	Transaction Description	Check Amount	Fund Code	Fund Short Title
24845	2/6/2019	Interwest Consulting Group	Building and Safety Services December 2018	15,565.30	10	GENERAL
Total 24845	2/6/2019			15,565.30		
24846	2/6/2019	Joe's Hardware	Supplies, Fire Station	13.98	10	GENERAL
Total 24846	2/6/2019			13.98		
24847	2/6/2019	NP Solutions, Inc.	2019 Abila Support Plan	595.00	10	GENERAL
Total 24847	2/6/2019			595.00		
24848	2/6/2019	County Executive Office	Miscellaneous Admin Expenses 2nd Qtr FY 18/19	1,002.57	10	GENERAL
Total 24848	2/6/2019			1,002.57		
24849	2/6/2019	Riverside Co. Recorders Office	Fee for Exemption for Adoption of City Wide Fee Resolution	50.00	10	GENERAL
Total 24849	2/6/2019			50.00		
24850	2/6/2019	RIV. CO. SHERIFF'S DEPT., Acctg & Fin	Contract Law Enforcement 11/8/18-12/5/18	122,414.56	10	GENERAL
Total 24850	2/6/2019			122,414.56		
24851	2/6/2019	SAFAI CORPORATION	Planning Deposit Refund for 22218 Tumbleweed Dr	893.00	10	GENERAL
24851	2/6/2019	SAFAI CORPORATION	Planning Deposit Refund for 23013 Pheasant Dr	893.00	10	GENERAL
24851	2/6/2019	SAFAI CORPORATION	Planning Deposit Refund for 23084 Canyon Lake Drive S	893.00	10	GENERAL
24851	2/6/2019	SAFAI CORPORATION	Planning Deposit Refund for 23977 Cruise Circle Dr	893.00	10	GENERAL
Total 24851	2/6/2019			3,572.00		

City of Canyon Lake
 Check/Voucher Register - Council Report - Expenditures
 From 2/1/2019 Through 2/28/2019

Check Num...	Matching Docum... Date	Vendor Name	Transaction Description	Check Amount	Fund Code	Fund Short Title
24852	2/6/2019	SOUTHERN CALIFORNIA EDISON	Electricity, Traffic Contol 12/28/18-1/29/19	381.40	20	GAS TAX
24852	2/6/2019	SOUTHERN CALIFORNIA EDISON	Electricity, Traffic Control 12/20/18-1/22/19	75.65	20	GAS TAX
Total 24852	2/6/2019			457.05		
24853	2/6/2019	STAPLES	Office Supplies	92.48	10	GENERAL
Total 24853	2/6/2019			92.48		
24854	2/6/2019	Synoptek, LLC	IT Services January 2019	2,436.00	10	GENERAL
Total 24854	2/6/2019			2,436.00		
24855	2/6/2019	Toshiba Financial Services	Copier Lease 1/15/19-2/15/19	725.25	10	GENERAL
Total 24855	2/6/2019			725.25		
24856	2/7/2019	Neil Safai	Planning Deposit Refund for 22218 Tumbleweed Dr	893.00	10	GENERAL
24856	2/7/2019	Neil Safai	Planning Deposit Refund for 23013 Pheasant Dr	893.00	10	GENERAL
24856	2/7/2019	Neil Safai	Planning Deposit Refund for 23084 Canyon Lake Drive S	893.00	10	GENERAL
24856	2/7/2019	Neil Safai	Planning Deposit Refund for 23977 Cruise Circle Dr	893.00	10	GENERAL
Total 24856	2/7/2019			3,572.00		
24857	2/20/2019	ANIMAL FRIENDS OF THE VALLEYS	Animal Control Services December 2018	7,000.00	10	GENERAL
Total 24857	2/20/2019			7,000.00		
24858	2/20/2019	BIO-TOX LABORATORIES	Sheriff's Dept Blood Testing January 2019	46.00	10	GENERAL

City of Canyon Lake
 Check/Voucher Register - Council Report - Expenditures
 From 2/1/2019 Through 2/28/2019

Check Numb...	Matching Docum... Date	Vendor Name	Transaction Description	Check Amount	Fund Code	Fund Short Title
Total 24858	2/20/2019			46.00		
24859	2/20/2019	Randall Bonner	Internet and Phone Reimbursement December 2018	80.00	10	GENERAL
Total 24859	2/20/2019			80.00		
24860	2/20/2019	Charles Abbott Associates, Inc.	Building and Safety Services January 2019	2,050.00	10	GENERAL
Total 24860	2/20/2019			2,050.00		
24861	2/20/2019	CANYON LAKE PEST CONTROL, Steven E. Young	Pest Control, Storage Unit	90.00	10	GENERAL
Total 24861	2/20/2019			90.00		
24862	2/20/2019	Cole Huber LLP	Attorney Services January 2019	9,784.52	10	GENERAL
Total 24862	2/20/2019			9,784.52		
24863	2/20/2019	DATA TICKET	Citation Processing Code Enforcement January 2019	100.00	10	GENERAL
24863	2/20/2019	DATA TICKET	Parking Citation Processing January 2019	100.00	10	GENERAL
Total 24863	2/20/2019			200.00		
24864	2/20/2019	DIRECTV	Satellite Service 2/12/19-3/11/19	87.57	10	GENERAL
Total 24864	2/20/2019			87.57		
24865	2/20/2019	STATE OF CA DEPT. OF JUSTICE	Sheriff's Dept Fingerprinting January 2019	64.00	10	GENERAL

City of Canyon Lake
 Check/Voucher Register - Council Report - Expenditures
 From 2/1/2019 Through 2/28/2019

Check Num...	Matching Docum... Date	Vendor Name	Transaction Description	Check Amount	Fund Code	Fund Short Title
Total 24865	2/20/2019			64.00		
24866	2/20/2019	Jordan Ehrenkranz	Internet Reimbursement February 2019	40.00	10	GENERAL
Total 24866	2/20/2019			40.00		
24867	2/20/2019	ELSINORE VALLEY MUNI WATER DIS	Water, Fire Detector 12/24/18-1/24/19	93.88	10	GENERAL
24867	2/20/2019	ELSINORE VALLEY MUNI WATER DIS	Water, Fire Station 12/28/18-1/28/19	217.65	10	GENERAL
24867	2/20/2019	ELSINORE VALLEY MUNI WATER DIS	Water, Irrigation 12/28/18-1/28/19	1,034.61	20	GAS TAX
Total 24867	2/20/2019			1,346.14		
24868	2/20/2019	Frontier Communications	City Hall, Internet 2/10/19-3/9/19	148.98	10	GENERAL
Total 24868	2/20/2019			148.98		
24869	2/20/2019	NANCY GREENHALGH	Retiree Health Insurance March 2019	163.37	10	GENERAL
Total 24869	2/20/2019			163.37		
24870	2/20/2019	Dawn Haggerty	Internet Reimbursement November and December	60.00	10	GENERAL
Total 24870	2/20/2019			60.00		
24871	2/20/2019	Jeremy Smith	Internet, Phone, Mileage/Parking Exp Reimb Jan & Feb 2019	306.87	10	GENERAL
Total 24871	2/20/2019			306.87		
24872	2/20/2019	Joe's Hardware	Supplies, Code Enforcement	9.69	10	GENERAL

City of Canyon Lake
 Check/Voucher Register - Council Report - Expenditures
 From 2/1/2019 Through 2/28/2019

Check Num...	Matching Docum... Date	Vendor Name	Transaction Description	Check Amount	Fund Code	Fund Short Title
Total 24872	2/20/2019			9.69		
24873	2/20/2019	K Graphics	Notice to Appear	616.44	10	GENERAL
Total 24873	2/20/2019			616.44		
24874	2/20/2019	Kasey Castillo	Parking Reimbursement February 2019	24.00	10	GENERAL
Total 24874	2/20/2019			24.00		
24875	2/20/2019	Kristine Gonzales	Plot Plan Deposit Refund 22529 Lighthouse 2017-242	893.00	10	GENERAL
Total 24875	2/20/2019			893.00		
24876	2/20/2019	Lake Chevrolet	Vehicle Maintenance 08 GMC Vin#9227	128.70	10	GENERAL
Total 24876	2/20/2019			128.70		
24877	2/20/2019	League of California Cities	Membership Dues 2019	5,990.00	10	GENERAL
Total 24877	2/20/2019			5,990.00		
24878	2/20/2019	Nate Volk	Broadcasting Services, Council Meeting 2/6/19	350.00	10	GENERAL
Total 24878	2/20/2019			350.00		
24879	2/20/2019	Pitney Bowes Global Financial Services, LLC	Postage Machine Lease 12/13/18-3/12/19	175.14	10	GENERAL
Total 24879	2/20/2019			175.14		
24880	2/20/2019	Purchase Power	Postage	400.00	10	GENERAL

City of Canyon Lake
 Check/Voucher Register - Council Report - Expenditures
 From 2/1/2019 Through 2/28/2019

Check Num...	Matching Docum... Date	Vendor Name	Transaction Description	Check Amount	Fund Code	Fund Short Title
Total 24880	2/20/2019			400.00		
24881	2/20/2019	Pitney Bowes - Reserve Account	Prepaid Postage	800.00	10	GENERAL
Total 24881	2/20/2019			800.00		
24882	2/20/2019	Rogers, Anderson, Malody & Scott, LLP	Accounting Services January 2019	6,700.00	10	GENERAL
Total 24882	2/20/2019			6,700.00		
24883	2/20/2019	Regional Conservation Authority	MSHCP Fees February 2019	2,104.00	50	AGENCY
Total 24883	2/20/2019			2,104.00		
24884	1/23/2019	JOHN REGUS	Library Lease March 2019	250.00	10	GENERAL
Total 24884	1/23/2019			250.00		
24885	2/20/2019	JOHN REGUS	Library Rent April 2019	1,074.62	10	GENERAL
Total 24885	2/20/2019			1,074.62		
24886	2/20/2019	RIV. CO. SHERIFF'S DEPT., Acctg & Fin	Contract Law Enforcement 12/6/18-1/2/19	123,291.92	10	GENERAL
Total 24886	2/20/2019			123,291.92		
24887	2/20/2019	SOUTHERN CALIFORNIA EDISON	Electricity, City Hall 1/14/19-2/13/19	692.04	10	GENERAL
24887	2/20/2019	SOUTHERN CALIFORNIA EDISON	Electricity, Fire Station 1/14/19-2/13/19	397.68	10	GENERAL
24887	2/20/2019	SOUTHERN CALIFORNIA EDISON	Electricity, Pump Station 1/8/19-2/7/19	34.21	20	GAS TAX
24887	2/20/2019	SOUTHERN CALIFORNIA EDISON	Electricity, Traffic Control 1/14/19-2/13/19	189.60	20	GAS TAX

City of Canyon Lake
 Check/Voucher Register - Council Report - Expenditures
 From 2/1/2019 Through 2/28/2019

Check Num...	Matching Docum... Date	Vendor Name	Transaction Description	Check Amount	Fund Code	Fund Short Title
Total 24887	2/20/2019			1,313.53		
24888	2/20/2019	Special District Risk Management Authority	Dental Insurance March 2019	51.61	10	GENERAL
Total 24888	2/20/2019			51.61		
24889	2/20/2019	Sparkletts	Drinking Water January 2019	29.05	10	GENERAL
Total 24889	2/20/2019			29.05		
24890	2/20/2019	STATE COMP. INS. FUND	Workers Comp March 2019	659.17	10	GENERAL
Total 24890	2/20/2019			659.17		
24891	2/20/2019	Structural Termite/Pest Control	Pest Control, Fire Station	36.75	10	GENERAL
Total 24891	2/20/2019			36.75		
24892	2/20/2019	Synoptek, LLC	IT Services February 2019	2,436.00	10	GENERAL
Total 24892	2/20/2019			2,436.00		
24893	2/20/2019	Time Warner Cable	Cable Service, Fire Station 2/10/19-3/9/19	99.98	10	GENERAL
Total 24893	2/20/2019			99.98		
24894	2/20/2019	U. S. Bank	Membership renewals, office supplies, student of the month	2,870.55	10	GENERAL
Total 24894	2/20/2019			2,870.55		
24895	2/20/2019	Verizon Wireless	Cell Phones, 1/4/19-2/3/19	391.21	10	GENERAL
24895	2/20/2019	Verizon Wireless	iPads, 1/4/19-2/3/19	208.90	10	GENERAL

City of Canyon Lake
 Check/Voucher Register - Council Report - Expenditures
 From 2/1/2019 Through 2/28/2019

Check Numb...	Matching Docum... Date	Vendor Name	Transaction Description	Check Amount	Fund Code	Fund Short Title
Total 24895	2/20/2019			600.11		
24896	2/20/2019	WRCOG	TUMF Fees February 2019	8,873.00	50	AGENCY
Total 24896	2/20/2019			8,873.00		
Report Total				363,213.23		

City of Canyon Lake
Invoices Selected for Payment - COUNCIL CHECK REPORT

Vendor ID	Invoice Description	Cash Required
ANIMAL FRIENDS	Animal Control Services December 2018	7,000.00
BIO-TOX	Sheriff's Dept Blood Testing January 2019	46.00
Bonner	Internet and Phone Reimbursement December 2018	80.00
Charles Abbott	Building and Safety Services January 2019	2,050.00
CL PEST	Pest Control, Storage Unit	90.00
Cole Huber	Attorney Services January 2019	9,784.52
DATA TICKET	Parking Citation Processing January 2019	100.00
	Citation Processing Code Enforcement January 2019	100.00
DIRECTV	Satellite Service 2/12/19-3/11/19	87.57
DOJ	Sheriff's Dept Fingerprinting January 2019	64.00
Ehrenkranz	Internet Reimbursement February 2019	40.00
EVMWD	Water, Fire Station 12/28/18-1/28/19	217.65
	Water, Irrigation 12/28/18-1/28/19	1,034.61
	Water, Fire Detector 12/24/18-1/24/19	93.88
Frontier	City Hall, Internet 2/10/19-3/9/19	148.98
GREENHALGH	Retiree Health Insurance March 2019	163.37
Haggerty	Internet Reimbursement November and December	60.00
Jeremy Smith	Internet, Phone, Mileage/Parking Exp Reimb Jan & Feb 2019	306.87
Joe's	Supplies, Code Enforcement	9.69
K Graphics	Notice to Appear	616.44
Kasey Castillo	Parking Reimbursement February 2019	24.00
Kristine Gonzales	Plot Plan Deposit Refund 22529 Lighthouse 2017-242	893.00
Lake Chevrolet	Vehicle Maintenance 08 GMC Vin#9227	128.70
LOCC	Membership Dues 2019	5,990.00
Nate Volk	Broadcasting Services, Council Meeting 2/6/19	350.00
Pitney Bowes	Postage Machine Lease 12/13/18-3/12/19	175.14
Pitney Bowes - Purchase Power	Postage	400.00
Pitney Bowes - Reserve Account	Prepaid Postage	800.00
RAMS	Accounting Services January 2019	6,700.00
RCA	MSHCP Fees February 2019	2,104.00
REGUS	Library Lease March 2019	250.00
	Library Rent April 2019	1,074.62
Riv Co Sheriff Acctg	Contract Law Enforcement 12/6/18-1/2/19	123,291.92
SCE	Electricity, Pump Station 1/8/19-2/7/19	34.21
	Electricity, Fire Station 1/14/19-2/13/19	397.68
	Electricity, Traffic Control 1/14/19-2/13/19	189.60
	Electricity, City Hall 1/14/19-2/13/19	692.04
SDRMA	Dental Insurance March 2019	51.61
Sparkletts	Drinking Water January 2019	29.05
STATE FUND	Workers Comp March 2019	659.17
Structural	Pest Control, Fire Station	36.75

Date: 2/20/19
03:17:28 PM

Page: 1

City of Canyon Lake
Invoices Selected for Payment - COUNCIL CHECK REPORT

<u>Vendor ID</u>	<u>Invoice Description</u>	<u>Cash Required</u>
Synoptek	IT Services February 2019	2,436.00
Time Warner	Cable Service, Fire Station 2/10/19-3/9/19	99.98
US Bank	Membership renewals, office supplies, student of the month	2,870.55
VerizonW	Cell Phones, 1/4/19-2/3/19	391.21
	iPads, 1/4/19-2/3/19	208.90
WRCOG	TUMF Fees February 2019	8,873.00
Report Total		<u>181,244.71</u>

City of Canyon Lake
Invoices Selected for Payment - COUNCIL CHECK REPORT

<u>Vendor ID</u>	<u>Invoice Description</u>	<u>Cash Required</u>
Neil Safai	Planning Deposit Refund for 22218 Tumbleweed Dr	893.00
	Planning Deposit Refund for 23013 Pheasant Dr	893.00
	Planning Deposit Refund for 23084 Canyon Lake Drive S	893.00
	Planning Deposit Refund for 23977 Cruise Circle Dr	893.00
Report Total		<u>3,572.00</u>

City of Canyon Lake
Invoices Selected for Payment - COUNCIL CHECK REPORT

Vendor ID	Invoice Description	Cash Required
Aflac	Supplemental Insurance January 2019	378.22
AMERICAN FORENSIC	Sheriff's Blood Draws December 2018	55.00
Control Pump	Install PLC/HMI Upgrade	21,681.00
	Install Interior Lighting	1,985.90
	Replace Faulty Limit Switch on Amiad Filter	464.00
Corelogic	Code Enforcement Data Base January 2019	5.00
	Code Enforcement Data Base January 2019	125.00
CTAI	Emergency Boulder Removal	250.00
	Cleanup Trees and Debris	1,100.00
	Median and Parkways Landscape Maintenance Service Jan 2019	5,000.00
	Fire Station Landscape Maintenance Service January 2019	250.00
GAS CO	Gas, 12/31/18-1/30/19	178.21
ICG	Building and Safety Services December 2018	15,565.30
Joe's	Supplies, Fire Station	13.98
NP Solutions	2019 Abila Support Plan	595.00
riv Co Exec	Miscellaneous Admin Expenses 2nd Qtr FY 18/19	1,002.57
Riv Co Recorder	Fee for Exemption for Adoption of City Wide Fee Resolution	50.00
Riv Co Sheriff Acctg	Contract Law Enforcement 11/8/18-12/5/18	122,414.56
SAFAI CORPORATION	Planning Deposit Refund for 23084 Canyon Lake Drive S	893.00
	Planning Deposit Refund for 22218 Tumbleweed Dr	893.00
	Planning Deposit Refund for 23977 Cruise Circle Dr	893.00
	Planning Deposit Refund for 23013 Pheasant Dr	893.00
SCE	Electricity, Traffic Control 12/20/18-1/22/19	75.65
	Electricity, Traffic Control 12/28/18-1/29/19	381.40
STAPLES	Office Supplies	92.48
Synoptek	IT Services January 2019	2,436.00
Toshiba	Copier Lease 1/15/19-2/15/19	725.25
Report Total		178,396.52

Department: (1) Staff

Code	Earning	Hours	Amount	Deduction	Code	Tax	Amount	Code	Tax	Amount	Taxable	Amount
Reg	Regular	7.00	420.00									
Emp Id	107											Gross 420.00
Rate	60.0000											Tot Lib 420.00
												Net Amt 420.00
Total Earnings		7.00	420.00	Total Deductions			0.00	Total Employer Taxes		0.00		0.00

Department: (1) Staff Total

Code	Earning	Hours	Amount	Deduction	Code	Tax	Amount	Code	Tax	Amount	Taxable	Amount
1	Reg	7.00	420.00									
1	Reg	7.00	420.00									Gross 420.00
0												Tot Lib 420.00
												Net Amt 420.00
Total Earnings		7.00	420.00	Total Deductions			0.00	Total Employer Taxes		0.00		0.00

Department: (20) City Employees

Code	Earning	Hours	Amount	Deduction	Code	Tax	Amount	Code	Tax	Amount	Taxable	Amount
125CO	125 Cash	492.43	264.97	PTAXI Pre-Tax P	CA	California SI	2593.12	CAETT	CA Edu & T	1302.73	1302.73	0.00
102	Hol	0.00			CASDI	CA SDI - Err	2858.09	CASUI	California SI	1302.73	1302.73	80.77
3785.25	Reg	2365.66		FITW Federal Inco	FITW	Federal Inco	2593.12	MED-R	Medicare - E	2858.09	2858.09	41.44
				MED Medicare	MED	Medicare	2858.09					
Total Earnings		9.50	2858.09	Total Deductions			264.97	Total Employer Taxes		367.09		122.21

Code	Earning	Hours	Amount	Deduction	Code	Tax	Amount	Code	Tax	Amount	Taxable	Amount
125CO	125 Cash	499.58	148.38	PTXPE Pre-Tax P	CA	California SI	2725.25	CAETT	CA Edu & T	2873.63	2873.63	0.00
98	Hol	237.40			CASDI	CA SDI - Err	2873.63	CASUI	California SI	178.16	178.16	0.00
24.9900	Reg	2136.65		FITW Federal Inco	FITW	Federal Inco	2725.25	MED-R	Medicare - E	2873.63	2873.63	41.67
				MED Medicare	MED	Medicare	2873.63					
Total Earnings		95.00	2873.63	Total Deductions			148.38	Total Employer Taxes		389.14		219.83

Code	Earning	Hours	Amount	Deduction	Code	Tax	Amount	Code	Tax	Amount	Taxable	Amount
125CO	125 Cash	452.83	338.54	PTXPE Pre-Tax P	CA	California SI	5530.96	CAETT	CA Edu & T	1130.50	1130.50	0.00
99	Hol	0.00			CASDI	CA SDI - Err	5869.50	CASUI	California SI	70.09	70.09	0.00
5416.67	Reg	5416.67		FITW Federal Inco	FITW	Federal Inco	5530.96	MED-R	Medicare - E	5869.50	5869.50	85.11
				MED Medicare	MED	Medicare	5869.50					
Total Earnings		95.00	5869.50	Total Deductions			338.54	Total Employer Taxes		964.31		155.20

Code	Earning	Hours	Amount	Deduction	Code	Tax	Amount	Code	Tax	Amount	Taxable	Amount
125CO	125 Cash	527.04	66.00	457B EE	CA	California SI	2610.60	CAETT	CA Edu & T	2838.39	2838.39	0.00
108	Hol	231.14	161.79	PTAXI Pre-Tax P	CASDI	CA SDI - Err	2838.39	CASUI	California SI	175.98	175.98	0.00
24.3300	Reg	1922.07		FITW Federal Inco	FITW	Federal Inco	2610.60	MED-R	Medicare - E	2838.39	2838.39	41.16
				MED Medicare	MED	Medicare	2838.39					
Total Earnings		95.00	2838.39	Total Deductions			227.79	Total Employer Taxes		282.19		217.14

Department: (20) City Employees Total

Code	Earning	Hours	Amount	Code	Deduction	Amount	Tax	Code	Amount	Tax	Code	Amount	Taxable	Amount
4	125CO	125 Cash	1971.88	457B	457B EE	66.00	CA	California SI	13459.93	CA Edu & Ti	CAETT	414.97	8145.25	0.00
2	Hol	Holiday	468.54	PTAXF	Pre-Tax P	426.76	CASDI	CA SDI - Err	14439.61	California SI	CASUI	144.40	505.00	Gross
2	Reg	Regular	11841.05	PTXPE	Pre-Tax P	486.92	FITW	Federal Incoi	13459.93	Medicare - E	MED-R	1234.00	209.38	Tot Liab
	Sick	Sick	158.14	MED	Medicare				14439.61			209.36		Net Amt
			209.00			14439.61			979.68			2002.73		714.38

Department: (30) Special Enforcement Team

Code	Earning	Hours	Amount	Code	Deduction	Amount	Tax	Code	Amount	Tax	Code	Amount	Taxable	Amount
Reg	Regular	58.50	1441.44	457B	457B EE	112.46	CA	California SI	1328.98	CA Edu & Ti	CAETT	11.96	1441.44	0.00
104				AflacP	Aflac Post	33.43	CASDI	CA SDI - Err	1441.44	California SI	CASUI	14.41	89.37	Gross
24.6400				FITW	Federal Incoi				1328.98	Medicare - E	MED-R	66.23	20.90	Tot Liab
				MED	Medicare				1441.44			20.90		Net Amt
						145.89			113.50			110.27		

Code	Earning	Hours	Amount	Code	Deduction	Amount	Tax	Code	Amount	Tax	Code	Amount	Taxable	Amount
Reg	Regular	33.00	915.09	457B	457B EE		CA	California SI	915.09	CA Edu & Ti	CAETT	12.18	915.09	0.00
83				AflacP	Aflac Post		CASDI	CA SDI - Err	915.09	California SI	CASUI	9.15	56.74	Gross
27.7300				FITW	Federal Incoi				915.09	Medicare - E	MED-R	82.73	13.27	Tot Liab
				MED	Medicare				915.09			13.27		Net Amt
						0.00			117.33			70.01		

Department: (30) Special Enforcement Team Total

Code	Earning	Hours	Amount	Code	Deduction	Amount	Tax	Code	Amount	Tax	Code	Amount	Taxable	Amount
125CO	125 Cash	74.00	228.02	PTAXF	Pre-Tax P	155.35	CA	California SI	2291.93	CA Edu & Ti	CAETT	93.09	2447.28	0.00
101	Reg	Regular	2219.26	AflacP	Aflac Post		CASDI	CA SDI - Err	2447.28	California SI	CASUI	24.48	151.73	Gross
29.9900				PTXPE	Pre-Tax P				2291.93	Medicare - E	MED-R	199.86	35.49	Tot Liab
				MED	Medicare				2447.28			35.48		Net Amt
						155.35			352.91			187.22		

Mike Borja, Acting City Manager
Date: 1/31/19

Department: (50)Council Members

Code	Earning	Hours	Amount	Deduction	Code	Tax	Amount	Code	Tax	Amount	Taxable	Tax	Amount	Taxable	Amount
Reg	Regular		300.00		CA	California SI	0.00	CAETT	CA Edu & Ti	0.00	300.00	300.00	0.00	300.00	0.00
Emp Id	78				FITW	Federal Incoi	0.00	CASUI	California SI	18.60	300.00	300.00	18.60	300.00	Gross
Salary	300.00				MED	Medicare	4.35	MED-R	Medicare - E	4.34	300.00	300.00	4.34	300.00	Tot Liab
															Net Amt
															295.65
Total Earnings															
		0.00	300.00	0.00			4.35			22.94					
Total Deductions															
		0.00	300.00	0.00			4.35			22.95					
Total Employer Taxes															
		0.00	300.00	0.00			4.35			22.95					
Total Earnings															
		0.00	300.00	0.00			4.35			22.95					
Total Deductions															
		0.00	300.00	0.00			4.35			22.95					
Total Employer Taxes															
		0.00	300.00	0.00			4.35			22.95					
Total Earnings															
		0.00	300.00	0.00			4.35			22.95					
Total Deductions															
		0.00	300.00	0.00			4.35			22.95					
Total Employer Taxes															
		0.00	300.00	0.00			4.35			22.95					
Total Earnings															
		0.00	300.00	0.00			4.35			22.95					
Total Deductions															
		0.00	300.00	0.00			4.35			22.95					
Total Employer Taxes															
		0.00	300.00	0.00			4.35			22.95					

Department: (50)Council Members Total

Code	Earning	Hours	Amount	Deduction	Code	Tax	Amount	Code	Tax	Amount	Taxable	Tax	Amount	Taxable	Amount
Reg	Regular		1500.00		CA	California SI	0.00	CAETT	CA Edu & Ti	0.00	1500.00	1500.00	0.00	1500.00	0.00
Emp Id	109				FITW	Federal Incoi	0.00	CASUI	California SI	18.60	1500.00	1500.00	18.60	1500.00	Gross
Salary	300.00				MED	Medicare	4.35	MED-R	Medicare - E	4.35	1500.00	1500.00	4.35	1500.00	Tot Liab
															Net Amt
															1478.25
Total Earnings															
		0.00	1500.00	0.00			21.75			114.74					
Total Deductions															
		0.00	1500.00	0.00			21.75			114.74					
Total Employer Taxes															
		0.00	1500.00	0.00			21.75			114.74					

Report Total

Employees	Code	Earning	Hours	Amount	Deduction	Code	Amount	Tax	Code	Amount	Tax	Code	Amount	Taxable	Amount	Taxable	Amount
6	125CO	125 Cash		2199.90	457B EE	CA	178.46	California SI	CAETT	532.20	CA Edu & T	CAETT	532.20	19495.93	14449.06	14449.06	0.00
7	Hol	Holiday	38.00	468.54	AflacP	CASDI	33.43	CA SDI - Err	CASUI	192.44	California SI	CASUI	192.44	19243.42	14449.06	14449.06	895.84
	Reg	Regular	337.00	18336.84	PTAXI Pre-Tax P	FITW	582.11	Federal Inco	MED-R	1582.82	Medicare - E	MED-R	1582.82	19495.93	20743.42	20743.42	300.78
	Sick	Sick	6.50	158.14	PTXPE Pre-Tax P	MED	486.92	Medicare		300.76			300.76	20743.42			300.78
		Total Earnings	381.50	21163.42	Total Deductions		1280.92	Total Employee Taxes		2608.22	Total Employer Taxes		1196.62				1196.62

Labor Distribution

City of Canyon Lake
Company (10756)

Check Date: 02/15/2019
Process: 2019021501
Period: 02/01/2019 to 02/15/2019

03/26/2019 Finance & Planning Committee

Department: (30)Special Enforcement Team

Code	Earning	Hours	Amount	Deduction	Code	Tax	Amount	Taxable	Code	Tax	Amount	Taxable	Amount
Reg	Regular	56.00	1379.84	457B EE ; AflacP; Aflac Post	CA	California SI	103.49	1276.35	CA	CA Edu & T	10.81	1379.84	0.00
Emp ID	104		33.43		CASDJ	CA SDI - Err		1379.84	CASUI	California SI	13.80	1379.84	85.55
Rate	24.6400				FITW	Federal Incon		1276.35	MED-R	Medicare - E	60.97	1379.84	20.01
					MED	Medicare		1379.84			20.01		1137.33
Total Earnings		56.00	1379.84	Total Deductions			136.92				105.59		105.56
Code	Earning	Hours	Amount	Deduction	Code	Tax <td>Amount</td> <td>Taxable</td> <td>Code</td> <td>Tax</td> <td>Amount</td> <td>Taxable</td> <td>Amount</td>	Amount	Taxable	Code	Tax	Amount	Taxable	Amount
Reg	Regular	34.00	942.82		CA	California SI		942.82	CA	CA Edu & T	12.79	942.82	0.00
Emp ID	83				CASDJ	CA SDI - Err		942.82	CASUI	California SI	9.43	942.82	58.45
Rate	27.7300				FITW	Federal Incon		942.82	MED-R	Medicare - E	86.06	942.82	13.67
					MED	Medicare		942.82			13.67		820.87
Total Earnings		34.00	942.82	Total Deductions			0.00				121.95		72.12
Code	Earning	Hours	Amount	Deduction	Code	Tax <td>Amount</td> <td>Taxable</td> <td>Code</td> <td>Tax</td> <td>Amount</td> <td>Taxable</td> <td>Amount</td>	Amount	Taxable	Code	Tax	Amount	Taxable	Amount
125CO	125 Cash		228.02	PTAXI Pre-Tax P.	CA	California SI	145.90	2166.43	CA	CA Edu & T	82.04	2105.44	0.00
Emp ID	101	63.50	1904.37		CASDJ	CA SDI - Err		2312.33	CASUI	California SI	23.12	2105.44	130.54
Rate	29.9900	6.00	179.94		FITW	Federal Incon		2166.43	MED-R	Medicare - E	184.80	2312.33	33.53
					MED	Medicare		2312.33			33.53		2312.33
Total Earnings		69.50	2312.33	Total Deductions			145.90				323.49		164.07

Department: (30)Special Enforcement Team Total

Code	Earning	Hours	Amount	Deduction	Code	Tax	Amount	Taxable	Code	Tax	Amount	Taxable	Amount
3	125CO 125 Cash		228.02	457B EE ;	CA	California SI	103.49	4385.60	CA	CA Edu & T	105.64	4428.10	0.00
Female	1	153.50	4227.03	AflacP; Aflac Post	CASDJ	CA SDI - Err		4634.99	CASUI	California SI	46.35	4428.10	274.54
Male	Sick	6.00	179.94	PTAXI Pre-Tax P.	FITW	Federal Incon		4385.60	MED-R	Medicare - E	331.83	4634.99	67.21
					MED	Medicare		4634.99			67.21		4634.99
Total Earnings		159.50	4634.99	Total Deductions			282.82				551.03		341.75

Report Total

Code	Earning	Hours	Amount	Deduction	Code	Tax	Amount	Taxable	Code	Tax	Amount	Taxable	Amount
7	125CO 125 Cash		2199.90	457B EE ;	CA	California SI	169.49	21192.37	CA	CA Edu & T	339.85	7472.61	0.00
Female	4	18.16	876.77	AflacP; Aflac Post	CASDJ	CA SDI - Err		22551.86	CASUI	California SI	225.53	7472.61	463.30
Male	3	11.00	274.89	PTAXI Pre-Tax P.	FITW	Federal Incon		21192.37	MED-R	Medicare - E	1124.08	22551.86	327.00
	Reg	294.50	17091.65	PTXPE Pre-Tax P.	MED	Medicare		22551.86			327.01		19142.47
	Retro		254.84										
	Sick	44.00	179.94										
	Vac	34.67	1673.87										
Total Earnings		402.33	22551.86	Total Deductions			1392.92				2016.47		790.30

Mike Borja, Acting City Manager
Date: 2/14/19

CREDIT CARD REVIEW

U S BANK Statement dated 1/7/19

ITEM #	CREDITOR	DESCRIPTION	AMOUNT	ACCOUNT
1	The League of California	New Mayors & Council Mem Academy registration-J Smith	\$ 575.00	10-100-6510
2	The League of California	New Mayors & Council Mem Academy registration-K Castillo	\$ 575.00	10-100-6510
3	Target	City council meeting	\$ 15.99	10-100-6510
4	Target	Office Supplies	\$ 19.01	10-310-6210
5	Vons	City council meeting	\$ 56.97	10-100-6510
6	Costco	Office Supplies	\$ 17.23	10-310-6210
7	Costco	City Council pictures	\$ 14.38	10-100-6510
8	Staples	Office Supplies	\$ 111.95	10-310-6210
9	AKI Homes	Office Supplies	\$ 41.98	10-310-6210
10	Int'l Code Council Inc	Building department code books and membership	\$ 1,444.97	10-360-6220
11	Fastsigns	City council name plates for wall	\$ 86.63	10-100-6510
12	Staples	Office Supplies	\$ 39.82	10-310-6210
13	Microsoft	Microsoft 365 Monthly Fee	\$ 432.50	10-310-6210
14	Canyon Lake Country Club	Monthly roundtable with POA and Water	\$ 23.20	10-310-6510
15	Canyon Lake Country Club	Economic Development Roundtable	\$ 10.08	10-310-6510
16	ICMA	Annual membership	\$ 1,040.00	10-310-6510
17				
			\$ 4,504.71	
		Account Breakdown		
	Council Meeting	10-100-6510		
	Council Special Dept. Expense	10-100-6520	\$ 1,323.97	
	Promotion and Advertising	10-100-6830		
	Office Expense	10-310-6210		
	Conference/Meeting/Travel Expense	10-310-6510	\$ 662.49	
	Professional/Specialized Services	10-310-6610	\$ 1,073.28	
	City Clerk Dues	10-320-6520		
	Professional/Specialized Services	10-320-6610		
	Building Dept Expense	10-360-6220		
	Fire Station Expenses	10-420-8018	\$ 1,444.97	
	Emergency Preparedness Supplies	10-425-6215		
	Code Enforcement Supplies	10-520-6210		
	Special Enforcement Misc Expense	10-520-6220		
	Code Enforcement Vehicle Equipment	10-520-6410		
	Vehicle Maintenance	10-520-6415		
	Code Enforcement Membership Dues	10-520-6520		
	Code Endoecement Training	10-520-6710		
			\$ 4,504.71	
			Check Figure \$	

Copies for City Council
as directed by
the Finance Committee

OK to pay
1/17-19
RBS

FEB 07 2019

BY: KL.....

U S BANK Statement dated 2/6/19

<u>ITEM #</u>	<u>CREDITOR</u>	<u>DESCRIPTION</u>	<u>AMOUNT</u>	<u>ACCOUNT</u>
1	Target		\$ 34.77	10-310-6210
2	Sam Renewal	Membership Renewal	\$ 299.00	10-310-6210
3	Western City Magazine	Advertisement	\$ 450.00	10-100-6830
4	Government Jobs	Advertisement	\$ 175.00	10-100-6830
5	National Notary Association	Notary	\$ 489.90	10-320-6520
6	CCAC	Membership Renewal	\$ 130.00	10-320-6710
7	Michaels	Wall frames	\$ 83.01	10-310-6210
8	Sanitaire Commercial Vacuum	Vacuum filters	\$ 52.62	10-310-6210
9	Jack in the Box	Student of the Month gift cards	\$ 35.00	10-100-6830
10	Amazon	Cardstock	\$ 24.95	10-100-6830
11	Eventbrite	2019 IE Vision Conference - Jereny Smith	\$ 35.00	10-100-6510
12	DIY Appliance Parts	Parts for Fire Station	\$ 36.99	10-420-6210
13	Eagles Mark	Veteran's Day Event	\$ 75.69	10-100-6830
14	Tru-Blue Cleaners	Skirts	\$ 69.00	10-310-6210
15	Microsoft	Microsoft 365 Monthly Fee	\$ 412.50	10-310-6210
16	LOCC		\$ (575.00)	10-100-6510
17		Late Fee	\$ 4.62	10-310-6210
Transactions not picked up from prior period statement:				
18	Microsoft	Microsoft 365 Monthly Fee	\$ 387.50	10-310-6210
19	LOCC		\$ 650.00	10-100-6510
			\$ 2,870.55	
Account Breakdown				
	Council Meeting	10-100-6510	\$ 110.00	
	Council Special Dept. Expense	10-100-6520		
	Promotion and Advertising	10-100-6830	\$ 760.64	
	Office Expense	10-310-6210	\$ 1,343.02	
	Conference/Meeting/Travel Expense	10-310-6510		
	Professional/Specialized Services	10-310-6610		
	City Clerk Dues	10-320-6520	\$ 489.90	
	Professional/Specialized Services	10-320-6610		
	City Clerk Training and Education	10-320-6710	\$ 130.00	
	Building Dept Expense	10-360-6220		
	Fire Station Expenses	10-420-6210	\$ 36.99	
	Emergency Preparedness Supplies	10-425-6215		
	Code Enforcement Supplies	10-520-6210		
	Special Enforcement Misc Expense	10-520-6220		
	Code Enforcement Vehicle Equipment	10-520-6410		
	Vehicle Maintenance	10-520-6415		
	Code Enforcement Membership Dues	10-520-6520		
	Code Endoecement Training	10-520-6710		
			\$ 2,870.55	
			Check Figure \$	

[Handwritten Signature]
2/20/19

*Copies for City Council
as directed by
the Finance Committee*

Skip to: Content | Footer | Welcome Kayla | Help | Contact Us | CalPERS Website | Log out **January 31, 2019**



Home Profile Reporting Person Information Education Other Organizations

Manage Reports Billing and Payments Payroll Schedule Member Requests Health Reconciliation Retirement Appointment Reconciliation

Name: City of Canyon Lake **CalPERS ID:** 3813045770

Payment Request Acceptance

Your request for payment has been accepted

- **To generate the employer payment report, please click the print button.**
- If you need to contact us with questions regarding this payment, please have your Payment Confirmation Number for faster access.
- Your payment will reflect as paid in myCalPERS if your payroll has successfully posted. Once your payment is processed any credits will roll over to the same type of receivable in the next month, after your payroll has been processed.
- Your payment may take longer to post, depending upon your Financial Institution.

Payment Setup Total

Total Payment Amount: \$136.69

Payment Summary

Payment Confirmation Number	Payment Authorization Date	Receivable ID	Receivable Description	Payment Method	Payment Account Nickname	Selected Payment Amount
1001252850	02/01/2019	100000015554030	Health PA Billing - PERS	EFT - Debit	Citizens Business Bank -5402	\$136.69

© Copyright 2019 CalPERS | [Conditions of Use](#) | [Accessibility](#)

Build: v7.8 Baseline: 190116_150942_v7.8_Int.9303 **UID: 318**

*OK to PM
2.3.19
JBS*

Skip to: Content | Footer | Welcome Kayla | Help | Contact Us | CalPERS Website | Log out **January 25, 2019**



Home Profile Reporting Person Information Education Other Organizations
 Manage Reports Billing and Payments Payroll Schedule Member Requests Health Reconciliation Retirement Appointment Reconciliation

Name: City of Canyon Lake **CalPERS ID:** 3813045770

Payment Request Acceptance

Your request for payment has been accepted

- **To generate the employer payment report, please click the print button.**
- If you need to contact us with questions regarding this payment, please have your Payment Confirmation Number for faster access.
- Your payment will reflect as paid in myCalPERS if your payroll has successfully posted. Once your payment is processed any credits will roll over to the same type of receivable in the next month, after your payroll has been processed.
- Your payment may take longer to post, depending upon your Financial Institution.

Payment Setup Total

Total Payment Amount: \$2,464.36

Payment Summary

Payment Confirmation Number	Payment Authorization Date	Receivable ID	Receivable Description	Payment Method	Payment Account Nickname	Selected Payment Amount
1001248558	01/25/2019	100000015519279	Employer Contribution, PEPPRA, 26189, CalPERS, 01/01/2019 - 01/15/2019	EFT - Debit	Citizens Business Bank -5402	\$957.80
1001248559	01/25/2019	100000015519234	Employer Contribution, Classic, 1684, CalPERS, 01/01/2019 - 01/15/2019	EFT - Debit	Citizens Business Bank -5402	\$1,506.56

© Copyright 2019 CalPERS | [Conditions of Use](#) | [Accessibility](#)

Build: v7.8 Baseline: 190116_150942_v7.8_Int.9303 UID: 318

NB
1/30/19

Skip to: Content | Footer | Welcome Kayla | Help | Contact Us | CalPERS Website | Log out January 31, 2019



Home Profile **Reporting** Person Information Education Other Organizations

Manage Reports Billing and Payments Payroll Schedule Member Requests Health Reconciliation Retirement Appointment Reconciliation

Name: City of Canyon Lake **CalPERS ID:** 3813045770

Payment Request Acceptance

Your request for payment has been accepted

- **To generate the employer payment report, please click the print button.**
- If you need to contact us with questions regarding this payment, please have your Payment Confirmation Number for faster access.
- Your payment will reflect as paid in myCalPERS if your payroll has successfully posted. Once your payment is processed any credits will roll over to the same type of receivable in the next month, after your payroll has been processed.
- Your payment may take longer to post, depending upon your Financial Institution.

Payment Setup Total

Total Payment Amount: \$2,115.92

Payment Summary

Payment Confirmation Number	Payment Authorization Date	Receivable ID	Receivable Description	Payment Method	Payment Account Nickname	Selected Payment Amount
1001252824	02/01/2019	100000015519303	Employer Contribution, PEPR, 26189, CalPERS, 01/16/2019 - 01/31/2019	EFT - Debit	Citizens Business Bank -5402	\$1,019.96
1001252825	02/01/2019	100000015519262	Employer Contribution, Classic, 1684, CalPERS, 01/16/2019 - 01/31/2019	EFT - Debit	Citizens Business Bank -5402	\$1,095.96

© Copyright 2019 CalPERS | [Conditions of Use](#) | [Accessibility](#)

Build: v7.8 Baseline: 190116_150942_v7.8_Int.9303 UID: 318

*OK for pay
2-5-19
RB*



CITY OF CANYON LAKE
PLAN SPONSOR: 0035273

Acknowledgment

Your payment was successfully submitted. Provided it is in good order, it will process within contractual timeframes.
You can print this acknowledgment for your records.

Plan Name: CITY OF CANYON LAKE 457

Plan Number: 0035273001

Payroll Center: CITY OF CANYON LAKE

Payroll Center Number: 001

Payroll Received for Salary Reduction

Submission date: 02/11/2019

Submission time: 01:33 PM

Pay period end date: 01/31/2019

Payment method: Debit ACH

Bank routing number: 122234149

Bank account number: 245125402

Contributions payment amount: \$132.00

Contributions count: 1

Draft date: 02/12/2019

Nationwide Retirement Solutions and Nationwide Life Insurance Company (collectively "Nationwide") have endorsement relationships with the National Association of Counties, the International Association of Fire Fighters-Financial Corporation, and the National Association of Police Organizations.

Nationwide may receive payments from mutual funds or their affiliates in connection with certain investment options. [Learn more about these payments.](#)

Retirement Specialists provide information for educational purposes only. This information is not meant to be used as investment advice. Retirement Specialists are Registered Representatives of Nationwide Investment Services Corporation, member FINRA.

SPS



CITY OF CANYON LAKE
PLAN SPONSOR: 0035273

Acknowledgment

Your payment was successfully submitted. Provided it is in good order, it will process within contractual timeframes.

You can print this acknowledgment for your records.

Plan Name: **CITY OF CANYON LAKE 457 OBRA-PST**

Plan Number: **0035273002**

Payroll Center: **CITY OF CANYON LAKE OBRA**

Payroll Center Number: **001**

Payroll Received for Salary Reduction

Submission date: **02/11/2019**

Submission time: **01:32 PM**

Pay period end date: **01/31/2019**

Payment method: **Debit ACH**

Bank routing number: **122234149**

Bank account number: **245125402**

Contributions payment amount: **\$220.84**

Contributions count: **1**

Draft date: **02/12/2019**

SLB

Nationwide Retirement Solutions and Nationwide Life Insurance Company (collectively "Nationwide") have endorsement relationships with the National Association of Counties, the International Association of Fire Fighters-Financial Corporation, and the National Association of Police Organizations.

Nationwide may receive payments from mutual funds or their affiliates in connection with certain investment options. Learn more about these payments. Retirement Specialists provide information for educational purposes only. This information is not meant to be used as investment advice. Retirement Specialists are Registered Representatives of Nationwide Investment Services Corporation, member FINRA.

INVESTMENT REPORT

CITIZENSTRUST™

PO Box 2549
Rancho Cucamonga, CA 91729-2549
Return Service Requested

RECEIVED

FEB 19 2019

BY: dlm

00000071 MCBBI000020719396625 01 000000 43 004

CITY OF CANYON LAKE
31516 RAILROAD CANYON RD
CANYON LAKE CA 92587

STATEMENT FOR THE PERIOD FROM 01/01/2019 TO 01/31/2019
ACCOUNT 1035003119

THIS IS YOUR REPORT OF INVESTMENTS AND TRANSACTIONS FOR THE PERIOD. INCLUDED
IN THE REPORT ARE

* PORTFOLIO: SUMMARY GRAPHICAL DISPLAY WITH MARKET VALUE & PERCENT

* ACTIVITY SUMMARY: MARKET VALUE WITH TRANSACTION SUMMARY

* PORTFOLIO STATEMENT: A LISTING OF COST AND MARKET VALUE OF ASSETS
HELD IN THE PORTFOLIO

COST BASIS APPLICABLE FOR CALCULATING CAPITAL GAINS AND LOSSES.
MARKET VALUE IS THE CURRENT VALUE OF EACH ASSET FOR MOST STOCKS AND BONDS.
MARKETS ARE THE CLOSING PRICES ON THE LAST TRADING DAY OF THE PERIOD.

* TRANSACTION STATEMENT: A COMPLETE LISTING FOR THE PERIOD GROUPED BY
TRANSACTION TYPE.

* DISCLOSURES: CITIZENS BUSINESS BANK MAY RECEIVE RESEARCH AND OTHER BENEFITS
FROM BROKER DEALERS WHICH MAY BE CONSIDERED COMPENSATION TO US. UPON REQUEST
WE WILL DISCLOSE DETAILS OF ANY COMPENSATION RECEIVED.

* TO TRUST BENEFICIARIES: UNDER SECTION 17200 OF CALIFORNIA PROBATE CODE,
YOU MAY PETITION THE COURT TO OBTAIN A COURT REVIEW OF THE ACCOUNT AND
THE ACTS OF THE TRUSTEE. CLAIMS AGAINST THE TRUSTEE FOR BREACH OF TRUST
MUST BE MADE WITHIN THREE YEARS FROM THE DATE OF RECEIPT OF AN ACCOUNTING
OR OTHER REPORT DISCLOSING FACTS GIVING RISE TO THE CLAIM.

Account Statement

Account Number: **1035003119**
 January 01, 2019 To January 31, 2019

CITY OF CANYON LAKE
 31516 RAILROAD CANYON RD
 CANYON LAKE, CA 92587

Account Name:	CITY OF CANYON LAKE CITIZENS BUSINESS BANK
Account Number:	1035003119
Your Relationship Manager Is:	MIKE GARDNER
Phone:	909-483-4390

Investment Portfolio Summary

Market Value As Of	01/01/2019	01/31/2019	% Of Account
CASH & CASH EQUIVALENTS	126,040.06	132,044.30	5.0%
FIXED INCOME	2,525,895.12	2,528,995.62	95.0%
Total	2,651,935.18	2,661,039.92	100.0%

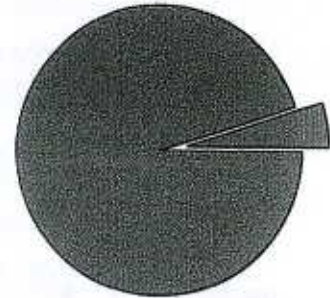

Activity Summary

	This Period	Year To Date	Realized Capital Gains / Losses	
			This Period	Year To Date
Beginning Market Value	2,651,935.18	2,651,935.18		
Income	5,305.75	5,305.75	Long Term	108.35-
Asset Activity	1,547.81	1,547.81	Total Gains / Losses	108.35-
Fees	849.32-	849.32-		
Cash Management	6,004.24-	6,004.24-		
Change In Market Value	9,104.74	9,104.74		
Ending Market Value	2,661,039.92	2,661,039.92		

Account Statement

Account Number: **1035003119**
 January 01, 2019 To January 31, 2019

Portfolio Statement

Quantity	Description	Market Value	Cost Basis
Cash & Cash Equivalents			
Cash Equivalents			
Unclassified			
132,044.300	31607A703 FIDELITY GOVERNMENT PORTFOLIO	132,044.30	132,044.30
	Total Unclassified	132,044.30	132,044.30
Total	Cash Equivalents	132,044.30	132,044.30
Total	Cash & Cash Equivalents	132,044.30	132,044.30
Fixed Income			
Taxable			
75,000.000	05531FAU7 BB&T CORPORATION DTD 06/29/15 CALL 2.625% 06/29/2020-2020	74,739.00	75,166.09
100,000.000	05580ACZ5 BMW BANK BANK NORTH AMERICA DTD 09/30/15 MEDIUM-TERM CD 2.2% 09/30/2020	99,068.62	99,980.00
100,000.000	14042RAR2 CAPITAL ONE NA MEDIUM-TERM CD DTD 10/07/2015 2.2% 10/07/2020	99,109.13	99,615.00
100,000.000	24422ERE1 JOHN DEERE CAPITAL CORP SERIES MTN DTD 07/12/2011 3.9% 07/12/2021	102,535.00	105,175.84
100,000.000	29266NS32 ENERBANK USA DTD 10/16/2015 MEDIUM-TERM CD 1.75% 10/16/2020	98,334.27	100,000.00
70,000.000	3130A1CE6 FEDERAL HOME LOAN DTD 03/27/14 2% 12/27/2019	69,634.60	70,231.64
100,000.000	3130A6NA1 FEDERAL HOME LOAN DTD 10/29/15 CALL 1.4% 10/29/2019-2016	99,178.00	100,000.00
50,000.000	3130A8EN9 FEDERAL HOME LOAN BANK DTD 06/14/16 CALL 1.64% 06/14/2021-2016	48,999.00	50,000.00
100,000.000	3130A8NT6 FEDERAL HOME LOAN DTD 07/13/16 CALL 1.48% 07/13/2021-2017	97,613.00	100,000.00
150,000.000	3130ADZ88 FEDERAL HOME LOAN DTD 4/17/18 3% 4/17/23 CALL 3% 04/17/2023-2019	150,058.50	150,000.00
100,000.000	313380FB8 FEDERAL HOME LOAN BANK DTD 08/09/12 1.375% 09/13/2019	99,290.00	99,667.18

Portfolio Statement (Continued)

Quantity	Description	Market Value	Cost Basis
Taxable			
100,000.000	3133EFZ91 FEDERAL FARM CREDIT BANK DTD 04/12/16 CALL 1.62% 04/12/2021-2017	98,027.00	99,909.00
200,000.000	3134G9J40 FREDDIE MAC DTD 07/26/16 CALL 1% 04/26/2019-2017	199,320.00	200,000.00
50,000.000	3134GAHK3 FREDDIE MAC DTD 09/30/16 CALL 1.6% 09/30/2021-2016	48,701.50	49,967.50
100,000.000	3134GAZR8 FREDDIE MAC DTD 12/30/2016 CALL 2.05% 12/30/2021-2017	98,421.00	100,000.00
100,000.000	3134GB7F3 FREDDIE MAC DTD 12/29/17 CALL 2.5% 12/29/2022-2018	99,305.00	100,000.00
100,000.000	3134GBZS4 FREDDIE MAC DTD 7/27/2017 CALL 2.15 4/27/2022 2.15% 04/27/2022-2017	98,258.00	100,000.00
150,000.000	3134GSYQ2 FREDDIE MAC DTD 9/27/2018 CALL 3% 09/27/2021-2019	150,418.50	149,902.50
50,000.000	3136G1C98 FANNIE MAE DTD 02/05/13 1.42% 02/05/2020	49,446.50	50,229.49
100,000.000	3136G3J30 FANNIE MAE DTD 07/28/16 CALL 1.6% 07/28/2021-2016	97,594.00	100,000.00
100,000.000	3136G3VG7 FANNIE MAE DTD 06/29/16 CALL 1.5% 09/29/2020-2016	98,391.00	100,000.00
100,000.000	3136G3XZ3 FANNIE MAE DTD 07/28/16 CALL 1.5% 07/28/2021-2016	97,102.00	100,000.00
100,000.000	3136G4EV1 FANNIE MAE DTD 10/28/16 CALL 1.625% 10/28/2021-2017	96,757.00	99,959.00
36,707.130	31398R7H2 FANNIE MAE SERIES 2010-M4 CLASS A3 DTD 07/01/10 3.819% 06/25/2020	37,013.25	39,276.63
200,000.000	69353REW4 PNC BANK NA DTD 04/29/16 CALL 2.15% 04/29/2021-2021	196,272.00	202,044.74
25,000.000	713448BN7 PEPSICO INC DTD 01/14/10 4.5% 01/15/2020	25,409.75	25,682.38
Total	Taxable	2,528,995.62	2,566,806.99

Account Statement

Account Number: **1035003119**
 January 01, 2019 To January 31, 2019

Portfolio Statement (Continued)

Quantity	Description	Market Value	Cost Basis
Fixed Income			
Total	Fixed Income	2,528,995.62	2,566,806.99
Miscellaneous			
Miscellaneous Sundry Assets			
Documents			
1.000	DOC199647 INVESTMENT MANAGEMENT AGREEMENT CITY OF CANYON LAKE A/C# 1035003119	0.00	0.00
	Total Documents	0.00	0.00
Total	Miscellaneous Sundry Assets	0.00	0.00
Total	Miscellaneous	0.00	0.00
Grand Total Assets		2,661,039.92	2,698,851.29

Account Activity Summary

	Total Cash	Cost Basis Excluding Cash	Market Value Including Cash
Balances Beginning Of Period	0.00	2,695,859.23	2,663,657.44
Prior Accruals			11,722.26-
Unrealized Appreciation This Period			9,213.09
Current Accruals			11,043.90
Asset Activity	1,547.81	1,656.16-	1,547.81
Cash Management	6,004.24-	6,004.24	6,004.24-
Fees	849.32-	0.00	849.32-
Income	5,305.75	1,356.02-	5,305.75
Realized Gain/loss			108.35-
Non Cash Asset Changes			
Balances End Of Period	0.00	2,698,851.29	2,672,083.82

Transaction Statement

Date	Quantity	Description	Transaction Type	Cash	Cost Basis
01/01/19		Beginning Balance		0.00	2,695,859.23
Income					
Interest					
01/02/19		31607A703 FIDELITY GOVERNMENT PORTFOLIO 24422ERE1	INTEREST RCVD	227.70	
01/14/19		JOHN DEERE CAPITAL CORP SERIES MTN DTD 07/12/2011 3.9% 07/12/2021	INTEREST RCVD	1,950.00	
01/14/19		3130A8NT6 FEDERAL HOME LOAN DTD 07/13/16 CALL 1.48% 07/13/2021-2017	INTEREST RCVD	740.00	

PO Box 2549
 Rancho Cucamonga, CA 91729-2549
 Return Service Requested

Account Number: **1035003119**
 January 01, 2019 To January 31, 2019

Transaction Statement (Continued)

Date	Quantity	Description	Transaction Type	Cash	Cost Basis
01/15/19		713448BN7 PEPSICO INC DTD 01/14/10 4.5% 01/15/2020	INTEREST RCVD	562.50	
01/16/19		29266NS32 ENERBANK USA DTD 10/16/2015 MEDIUM-TERM CD 1.75% 10/16/2020	INTEREST RCVD	148.63	
01/25/19		31398R7H2 FANNIE MAE SERIES 2010-M4 CLASS A3 DTD 07/01/10 3.819% 06/25/2020	INTEREST RCVD	121.75	
01/28/19		3136G3J30 FANNIE MAE DTD 07/28/16 CALL 1.6% 07/28/2021-2016	INTEREST RCVD	800.00	
01/28/19		3136G3XZ3 FANNIE MAE DTD 07/28/16 CALL 1.5% 07/28/2021-2016	INTEREST RCVD	750.00	
01/28/19		31398R7H2 FANNIE MAE SERIES 2010-M4 CLASS A3 DTD 07/01/10 3.819% 06/25/2020	INTEREST RCVD	5.17	
Total Interest				5,305.75	0.00
Total Income				5,305.75	0.00
Asset Activity					
Assets Sold					
01/25/19	1,547.810-	31398R7H2 FANNIE MAE SERIES 2010-M4 CLASS A3 DTD 07/01/10 3.819% 06/25/2020	NOTE AND MTG PMT	1,547.81	1,656.16-
01/28/19		31398R7H2 FANNIE MAE SERIES 2010-M4 CLASS A3 DTD 07/01/10 3.819% 06/25/2020	NOTE AND MTG PMT		
Total Assets Sold				1,547.81	1,656.16-
Total Asset Activity				1,547.81	1,656.16-
Fees					
01/28/19		MANAGEMENT FEES CITIZENS BUSINESS BANK FOR THE PERIOD ENDING 01/20/2019	DISBURSEMENT	849.32-	
Total Fees				849.32-	0.00
Cash Management					
01/31/19	6,004.240	31607A703 NET CASH MANAGEMENT	NET CASH MGMT	6,004.24-	6,004.24
Total Cash Management				6,004.24-	6,004.24
Miscellaneous					
01/14/19		24422ERE1 AMORTIZATION ON 100,000 UNITS JOHN DEERE CAPITAL CORP SERIES MTN DTD 07/12/2011 3.9% 07/12/2021 EFFECTIVE 01/12/2019 TO ADJUST TAX LOT, AMORTIZATION = 1,016.52-	AMORTIZATION		1,016.52-

Account Statement

Page 6

Account Number: **1035003119**

January 01, 2019 To January 31, 2019

Transaction Statement (Continued)

Date	Quantity	Description	Transaction Type	Cash	Cost Basis
01/15/19		713448BN7 AMORTIZATION ON 25,000 UNITS PEPSICO INC DTD 01/14/10 4.5% 01/15/2020 TO ADJUST TAX LOT, AMORTIZATION = 339.50-	AMORTIZATION		339.50-
Total Miscellaneous				0.00	1,356.02-
01/31/19		Ending Balance		0.00	2,698,851.29

Disclosure

1099S WILL BE POST-MARKED ON OR BEFORE FEBRUARY 28TH UNLESS THE ACCOUNT HOLDS COMPLEX ASSETS (REITS, GNMA, FNMA, OTHER GOV'T AGY) OR MASTER LIMITED PARTNERSHIPS (MLPS). THE LATTER WILL BE POST-MARKED BY MARCH 18TH. MAILING OF FIDUCIARY TAX INFORMATION WILL BEGIN MID-FEBRUARY AND CONTINUE THROUGH EARLY APRIL.

EXPENSE REPORT

2019 Expense Reports

	January	February	March	April	May	June	July	August	September	October	November	December
Randall Bonner												
Internet												
Cell Phone												
Travel												
Total	\$ -	\$ -	\$ -	\$ -	\$ -	\$ -	\$ -	\$ -	\$ -	\$ -	\$ -	\$ -
Kasey Castillo												
Internet												
Cell Phone												
Travel	\$ 12.00	\$ 12.00										
Total	\$ 12.00	\$ 12.00	\$ -	\$ -	\$ -	\$ -	\$ -	\$ -	\$ -	\$ -	\$ -	\$ -
Jordan Ehrenkranz												
Internet	\$ 40.00	\$ 40.00										
Cell Phone												
Travel												
Total	\$ 40.00	\$ 40.00	\$ -	\$ -	\$ -	\$ -	\$ -	\$ -	\$ -	\$ -	\$ -	\$ -
Larry Greene												
Internet												
Cell Phone												
Travel												
Total	\$ -	\$ -	\$ -	\$ -	\$ -	\$ -	\$ -	\$ -	\$ -	\$ -	\$ -	\$ -
Jeremy Smith												
Internet	\$ 40.00	\$ 40.00										
Cell Phone	\$ 46.56	\$ 46.43										
Travel	\$ 146.96	73.48										
Total	\$ 233.52	\$ 159.91	\$ -	\$ -	\$ -	\$ -	\$ -	\$ -	\$ -	\$ -	\$ -	\$ -

**City of Canyon Lake
City Council
Staff Report**

TO: Finance & Planning Committee

FROM: Mike A. Borja, Acting City Manager 

DATE: March 5, 2019

SUBJECT: Authorization to Purchase Golf Community Caution Signs with Statewide Traffic Safety & Signs

Recommendation

That the City Council authorize the Acting City Manager to purchase two (2) golf community caution signs from Statewide Traffic Safety & Signs for the purpose of informing commuters traveling through to slow down.

Background

With Canyon Lake known as a golf community that allows golf cart owners to cross Railroad Canyon Rd., it was requested by Councilmember Smith to purchase and install two (2) solar powered flashing caution signs on both ends of Railroad Canyon Road, that indicate "Slow Down - Entering Golf Community" to encourage commuters traveling through to slow down. Staff reached out to Statewide Traffic Safety & Signs, who the city has used in the past to order their street signs for Railroad Canyon Rd.

Fiscal Impact

Statewide Traffic Safety & Signs provided a cost proposal of \$3329 for two (2) solar powered, customs signage, and assembly parts. Installation cost is estimated to be between \$500 - \$1000. At most, total cost for project is approximately \$4329.

Attachments

1. Sales Quote - Statewide Traffic Safety & Signs
2. Additional Quotes

ATTACHMENT 1



DATE	02/27/2019		
TO	MIKE BORJAS CITY OF CANYON LAKE		
EMAIL	mbaray@stssi.com		
FROM	Mayra Baray STATEWIDE TRAFFIC SAFETY & SIG	PHONE NUMBER	FAX NUMBER
SUBJECT	QUOTE 13002438		

www.statewidesafety.com



STATEWIDE RIVERSIDE
2225 KANSAS AVE
RIVERSIDE, CA 92507

Sales Quotation

QUOTE #	13002438
LOCATION	13
DATE	02/27/19
PAGE	1 of 1

BILL TO

S1268101
CITY OF CANYON LAKE
31516 RAILROAD CANYON RD
CANYON LAKE, CA 92587-9400

SHIP TO

CITY OF CANYON LAKE/YARD
31516 RAILROAD CANYON RD
CANYON LAKE, CA 92587-9400

QUOTE DATE 02/27/19	EXPIRE DATE 03/29/19	REQUIRED DATE	REFERENCE NUMBER	PAYMENT TERMS NET 60
WRITTEN BY Mayra Baray			CONTACT MIKE BORJAS	SHIP VIA DROP SHIP
FREIGHT TERMS PREPAID		JOB NUMBER 998		SALES REP Mayra Baray

PRODUCT/DESCRIPTION	QUANTITY	PRICE	U/M	EXTENSION
---------------------	----------	-------	-----	-----------

*SO BlinkerSign, 36", DG3, Solar, "Slow Down-Entering Golf Commu	2	1475.000	EA	2,950.00
--	---	----------	----	----------

MERCHANDISE TOTAL	HANDLING	MISC CHARGE	TAX	FREIGHT	QUOTE TOTAL
2,950.00	0.00	0.00	228.63	150.00	3,328.63

Accepted:

By: _____

Date: _____

ATTACHMENT 2



My Account

Search products...

Home Shop Company Gallery Blog Contact

\$7,040.00 2 items

Warning Signs TS40 Crosswalk Flashing Sign Package (W11-2)



TS40 Crosswalk Flashing Sign Package (W11-2)

\$2,770.00 – \$10,280.00

- Includes two TS40 Pedestrian Flashing LED Edge Lit Signs (W11-2).
- High intensity LEDs extend the visibility of the sign.
- Solar or AC powered.
- Fast, easy installation, low maintenance.
- MUTCD section 2A.07 compliant.
- Sign lead time 2-3 weeks.

Power Type

Solar

Sheeting

Type IX

LED Color

White

Size

36" (X2)

Activation

24/7 Flashing (standard)

Clear

\$3,520.00

Add to cart

SKU: SI-TS40-W11-2-PKG-1

Categories: [All Signs](#), [Sign Packages](#), [Pedestrian Signs](#), [Warning Signs](#)

Cart

TS40 Crosswalk Flashing Sign Package (W11-2)
2 x \$3,520.00

Subtotal: \$7,040.00

View Cart

Checkout

Product Categories

- All Signs
- Sign Packages
- Pedestrian Signs
- Stop Signs
- School Zone Signs
- Warning Signs
- Regulatory Signs
- Speed Signs
- Railroad Signs
- Clearance Signs
- Custom Signs
- Hand Held Signs

Recent Posts

Wrong Way Warning Flashing LED Signs





Call us 7 days a week
1.888.978.7759
Click to Chat

Log In | View Cart | Contact Us | Track Order | Quick

2 Items - (\$3,468.00)

Shop Categories

Help

Welcome Log In
Account Tools

(0)
Lists

Submit C

Shopping Cart

Item	Item Number	Price	Quantity	Add-ons	Print Cart	Email Cart	Save C
 <p>Tapco® 2180-00232 BlinkerSign® Flashing LED Pedestrian Crossing Sign W11-2, 36"W, Solar globalindustrial.com Shipping: Usually ships in 5 to 8 days</p>	WRB1504131	\$1,734.00	2				
					<p>Subtotal (2 Items) \$3,468.00</p> <p>Calculate shipping</p>		
<p>Delete Keep for Later</p>							

Please note: When using PayPal shipping address selected in PayPal override the one selected on the Global Industrial website.



Need More Information?

Information about our 30 Day Satisfaction Guaranteed Return Policy, Shipping, Rebates and more is available through [help](#). For further assistance, please call 1-888-628-3466 or email service@globalindustrial.com.

Our Commitment to Security

GlobalIndustrial.com is dedicated to making sure that you enjoy a secure shopping experience. This site has security measures in place to protect the loss, misuse and alteration of the information under our control, including 128-bit encryption technology and Secure Socket Layers (SSL) in all areas where your personal identity is required.

Amex Express Checkout

When using Amex Express Checkout, American Express will share the following personal information with us, your first name, last name, email address and postal address, including city, state, country and postal code. The use of this information by us is subject to our privacy policy.

Privacy Policy

GlobalIndustrial.com is committed to protecting your privacy. We will not distribute your Personal Information, except as stated in the [Privacy Policy](#). If you are interested in learning more about our efforts to provide a secure shopping environment, please read our [privacy policy](#).

Shipping Charges *

Shipping charges are based upon weight, dimensions, distance traveled and type of shipping service you specify (ground, next day, second day).

All shipments are F.O.B. shipping point. Shipping method is determined by size and weight of each item. Items of differing size and weight may ship independently, by different methods, even if ordered together. Items that are too large or too heavy for UPS will be shipped motor freight. Someone must be present to accept truck deliveries. Standard truck delivery is to a facility with a dock designed to receive freight. Twenty-four hour notification, residential deliveries, lift gate, or inside deliveries are available each with an additional charge.

To view shipping charges, use the Shipping Calculator featured in the Shopping Cart. Unless otherwise stated, freight and shipping fees will be charged for shipments to anywhere in the contiguous United States, using a carrier of our choice. Other terms apply to Alaska, Hawaii, Puerto Rico, and export orders. Any extra charges incurred for additional services, such as customer's carrier or special handling by the carrier, must be paid by the consignee. Items backordered from an order qualifying for prepaid shipping charges will be shipped prepaid. Title and risk of loss pass to the customer upon tender of shipment to the carrier. Certain restrictions apply to Free Shipping promotions. These include use of our choice of carriers and shipping methods as well as other limitations.

Collect Shipments - We will gladly ship via your specified carrier however, we will not ship with certain carriers due to poor experience.

TRANSIT TIME: *

UPS Ground: 3 - 8 Business Days

Recently Viewed Items

 Tapco® 2180-0023 BlinkerSign® Flashi
\$1,734.00

Qty: [Add](#)

current sign design

version **A**



36" Diamond, 2.25" Rad w/(2) 3/8" holes 36" apart on center

C1900616

Customer	Statewide Safety & Signs
Customer #	C27846
Sales order #	SO Q1903349
Sales person	Courtney J
File name	Q1903349 .fs

By checking "Approves for Production" and signing below, customer agrees to purchase sign as it appears on this artwork proof. Once this approval is received by TAPCO production will begin and any changes and/or cancellations will not be possible.

Customer...	date & signature
... approves for production <input type="radio"/>	<input type="text"/>
... requests changes / additions <input type="radio"/> (please describe below)	<input type="text"/>

**City of Canyon Lake
City Council
Staff Report**

TO: Finance & Planning Committee

FROM: Mike A. Borja, Acting City Manager 

DATE: March 5, 2019

SUBJECT: Discussion of Goetz Road's Eastport and Audie Murphy Intersection Light Reconfiguration

Recommendation

Discussion of reconfiguring the intersection light at Eastport and Audie Murphy at Goetz Road with the City of Menifee.

Background

At the request of City Council, staff was directed to investigate vehicle turning movements at the intersection of Audie Murphy / Eastport at Goetz Road. The concern of the intersection is left lane turning movements leaving Audie Murphy and right turning movements coming out of Canyon Lake (Eastport), all trying to head south on Goetz Rd. There have been incidents where vehicles trying to cross over to the farthest lane and colliding in the middle in order to position themselves so they can turn onto Railroad Canyon Road/Newport Road and proceed either east or west.

City staff directed City Planner Jim Morrissey to make contact the City of Menifee's Traffic Engineer to discuss possible options. After several discussions, two options were presented by Menifee's Traffic Engineer as possible solutions:

1. Split Phase Sequence – Change the light configuration where the light is green on the Menifee side and red on the Canyon Lake side. That way one side is stopped while the other is moving. At present the signals are both green at the same time and turning movements are conflicting. The split phase sequence would require a change in the signal arms themselves, with an estimate for new signals and their installation could be between \$3,000.00 to \$4,000.00. It was suggested because this intersection affects both the City of Menifee and Canyon Lake that potential a cost sharing method could be discussed.
2. No Turn On Red Sign – Add a sign that reads “No Turn On Red” in which you can only proceed when the green light is on. This however would cause traffic delays at the intersection and would probably be unwelcome by residents. Cost would be only to purchase the sign and install. No cost for reprogramming the light sequence.

Even though a 'No Turn On Red' sign is less costly, staff is recommending option 1 - Split Phase Sequence Configuration, because of the potential traffic delay that option 2 could cause for residents driving out of Eastport.

Fiscal Impact

Estimates from the City of Menifee could be between \$3,000 to \$4,000, with a potential of cost sharing the expense between both cities. City staff is waiting the City of Menifee on final numbers before the project moves forward.

Attachments

N/A

**City of Canyon Lake
City Council
Staff Report**

TO: Honorable Mayor and Members of the City Council

FROM: Mike A. Borja, Acting City Manager

DATE: March 5, 2019 

SUBJECT: Discussion of Lease Proposal with Dish Network

Recommendation

Discussion of lease proposal with Dish Network to allow them to place or install their technology at Fire Station 60 for a preservation project with Dish Network service.

Background

NextEdge Networks has partnered with Dish Network to help locate and place their technology with municipalities for the potential of service projects in their areas. Dish Network, with the help of NextEdge have chosen Canyon Lake, California as a potential candidate for property use.

Dish Network purchased Spectrum a few years ago, and per their agreement, they must build on its service or relinquish it back to Spectrum. Dish Network is creating a weather channel as a place holder until they decide what they want to build out on it, and they must meet the FCC deadline to begin building on it by April 1, 2019. This project is nationwide which will include deploying 1000 satellites for this weather channel. Through the help of NextEdge, the city's Fire Station 60 has been chosen as one many location for the weather channel.

What Dish Network propose to do is to lease two small spaces at the Fire Station 60, which is located at 28730 Vacation Drive, to install equipment on the rooftop and the accompanying electrical unit inside the building. Here's the detail of the project and the compensation that's offered to the City:

- Rooftop space of 4' x 4' and an interior wall space of 2' x 2' for this equipment
- One (1) standard available outlet is needed nearby the electrical equipment
- Equipment will be installed for up to 3 years
- Compensation is \$1,200 a year, \$3,600 total for three (3) year term

Fiscal Impact

No Fiscal Impact to the City's General Fund. City will be compensated a total of \$3600 upon execution of the agreement.

Attachments

1. License Agreement with Dish Network
2. Project Overview with Station 60 Aerial

ATTACHMENT 1

LICENSE AGREEMENT

This License Agreement ('Agreement') dated _____, 2019 ('Effective Date') between _____, a _____, with its principal offices located at _____ ("Licensor") and NextEdge Networks, LLC, a Delaware Limited Liability Company with its principal offices at 240 Stockton Street, 3rd Floor, San Francisco, CA 94108 ("NextEdge").

Grant: Licensor grants to NextEdge a non-exclusive license to install, maintain, repair, operate, inspect, augment and remove, at NextEdge's expense, a dish, cable(s), conduit and other equipment as described in Exhibit A, attached hereto and incorporated herein (the "Equipment") on the Property, located at _____. **The Equipment, requiring an interior wall space of 2' x 2' for its electrical equipment, conduit and a 4'x4' rooftop space for the A-Equipment and additional space for the B-Equipment (the "Space"), will be placed in a mutually agreed upon location within the Property.** This Agreement is contingent upon the Licensor's approval of the Equipment location(s). Licensor also grants to NextEdge the use of one (1) standard 110 VAC outlet located within or near the Space. Licensor shall allow NextEdge, as well as its employees, agents, contractors, partners, representatives and assigns reasonable access to the Property and Space **during normal business hours for repair, upgrade, replacement, or maintenance of the Equipment. In the event of an emergency after hours, Licensor will make reasonable effort to allow NextEdge access to the Property.** Licensor and NextEdge are aware and agree that the NextEdge will sublicense the Space to a DISH Network during this Term. NextEdge's sublicense Agreement with Dish will accommodate and allow for NextEdge's continued use of the Property.

Term: This Agreement shall have a Term three years (3 years), the Initial Term ("Initial Term"), commencing on the date of full execution by Licensor and NextEdge of this agreement. In consideration for this Agreement, NextEdge will pay the Licensor an upfront annual fee of _____ Dollars (\$ _____), to be paid within thirty business days of installation. At the expiration of the initial Term, this Agreement shall automatically renew on a month-to-month basis if NextEdge has not terminated the Agreement in writing prior to, or has not removed their Equipment, hereinafter referred to as holdover period ("Holdover"). In this event, NextEdge and the Licensor will be required to renegotiate the Term and annual fee of this Agreement. During this Holdover period, either party may terminate this Agreement by providing thirty (30) days written notice.

NextEdge's Obligation: NextEdge shall keep the Equipment in good order. Upon written Notice from the Licensor, NextEdge shall repair physical damage created by NextEdge at or adjacent to the Space in a timely manner, to a condition as nearly as is reasonably possible, existing prior to such damage being caused by NextEdge or its agents. NextEdge is not responsible for normal wear and tear at, or adjacent to, the Space. NextEdge will maintain a general liability insurance in the amount of one million dollars (\$1,000,000.00) during the life of this Agreement and shall name the Licensor as additional insured.

Non-interference: NextEdge agrees that Equipment shall not unduly interfere with Licensor use, maintenance or operation of the Property and any existing communication system(s) installed at the Property. In the event the Equipment causes demonstrated interference, Licensor shall notify NextEdge in writing and NextEdge shall make the necessary alterations at its expense.

Notices: All notices ("Notice") under this Agreement shall be written and given by certified mail, return receipt requested, nationally recognized overnight courier service such as Federal Express or UPS, or hand delivered to the respective address of each party as set forth below (or as may subsequently be provided by either party).

Licensor:
Attention:
Address:
Emergency Contact Name:
Emergency Contact Email:

NextEdge:
Attention:
Address:
Emergency
Emergency Email

Termination: **NextEdge may terminate this Agreement by providing thirty (30) days prior written notice to the Licensor.** Upon the expiration or termination of this Agreement by NextEdge, NextEdge shall remove the Equipment from the Property within thirty (30) business days. Licensor may terminate this Agreement at the end of the initial Term or any time thereafter, upon thirty (30) days written notice to NextEdge. Licensor represents and warrants that Licensor has rights in the Property sufficient to grant the license to NextEdge upon execution of this Agreement and shall retain said rights throughout the initial Term. The result of early termination with no reasonable notice by the Licensor will result in default and action by NextEdge, with possible financial implication.

Assignment: NextEdge has the right to assign this Agreement without notice to or consent of Licensor. In the event of an assignment, all terms and conditions of this Agreement remain in full force. Licensor may not assign this Agreement without the written authorization of NextEdge, which shall not be unreasonably withheld.

Amendment: Neither party may amend this Agreement except in writing signed by Licensor and NextEdge.

Miscellaneous: Each party acknowledges that: (a) this is the entire agreement between the parties; (b) Licensor is not relying on any representation or assurance of any nature whatsoever (whether or not in writing) made or given by any person (whether or not a party to this Agreement) that is not expressly set out in this Agreement (nothing in this Agreement shall have the effect of limiting or excluding any liability for, or remedy in respect to fraud); and (c) this Agreement is governed by, and construed in accordance within the laws of the state where the Licensor is located..

WITNESS WHEREOF, each of the persons executing this Agreement affirms that he or she has the complete authority to enter into this Agreement on behalf of the party for which he or she is signing, and to bind said party to the terms contained herein as of the last date signed.

Licensor:

NextEdge Networks, LLC

Signature: _____

Signature: _____

Name:

Name: Doug Wiest

Title: _____

Title: CEO

Date: _____

Date: _____

Exhibit A
NextEdge's Equipment

A-EQUIPMENT



INTERIOR EQUIPMENT

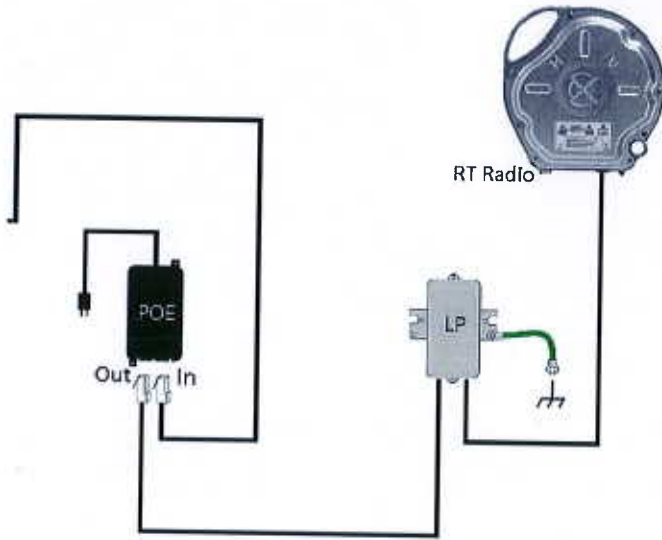

B-EQUIPMENT

ATTACHMENT 2

Dish Network Project Overview

- Dish Network is proposing to lease at least two (2) small spaces on your property to install their equipment, which serves to fulfill their requirements with the FCC.
- Leased Space #1: A rooftop space of approximately 4' x 4' for the dish.
- Leased Space #2: Interior wall space of approximately 2' x 2' for electrical equipment.

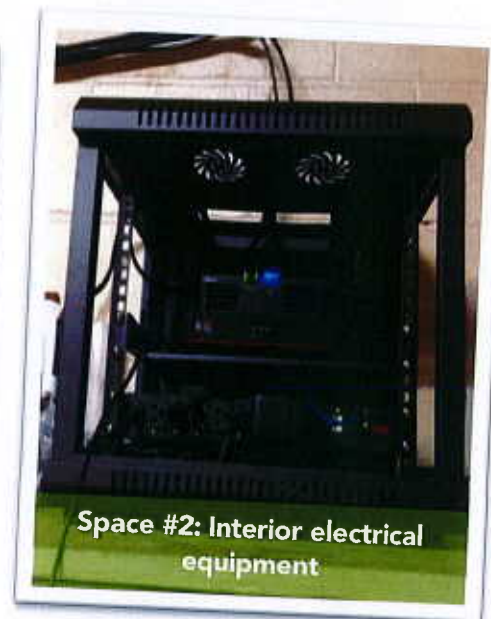
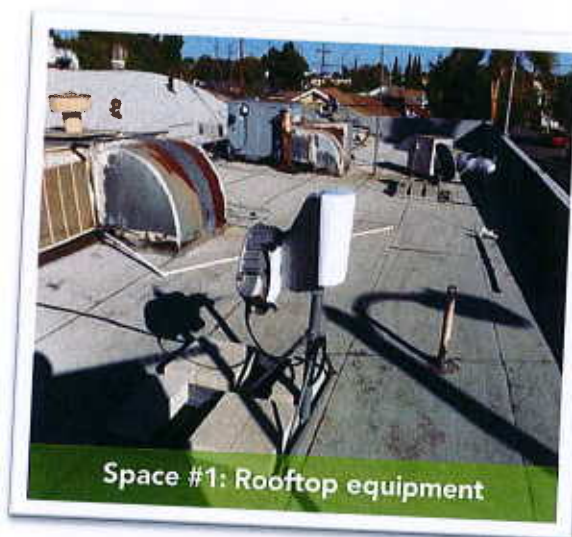

How we install:

- A Dish Network representative will visit your property within the next 24 to 48 hours to assess if we will be able to install this equipment on your property.
- NextEdge will be responsible for maintaining, repairing, operating and removing this equipment.

About the equipment:

- The rooftop equipment weighs approximately 10.6 pounds and is 12" x 11.5" x 4".
- The electrical equipment is 14.5" x 24" x 18".
- We also need to use one (1) standard 110 VAC outlet near the location of the equipment.

About the project:

- To assist with your research, we encourage you to visit NextEdgeNetworks.com
- NextEdge Networks is a subcontractor of Dish Network. We procure lease agreements with property owners to perform the installation of technology throughout the U.S.
- Chris Maguire, CFO of NextEdge Networks, will be the signing party of this agreement. His profile can be found here: <http://nextedgenetworks.com/about-us/>

